

BAT-1

Battery voltage and current monitor

Operating Manual – English 1.03



Introduction

The BAT-1 is a 2.25" instrument used to monitor your aircraft's battery power supply. It can be used on lead-acid, NiCad batteries as well as gel cells. This instrument is very useful in determining your battery's health, charging status, as well as the current load consumption of your aircraft. The BAT-1 can be used in both 12V and 24V aircraft and can measure voltages up to 30V DC.

The BAT-1 uses standard current shunts and is able to measure currents in the range of 5A to 500A. The instrument contains a programmable low/high voltage alarm to automatically detect bad batteries and alternator failures.

1 Features

- Measure voltage and current simultaneously
- Can measure voltages up to 30V (compatible with both 12V and 24V aircraft supplies)
- Contains a programmable low/high voltage alarm to automatically detect alternator failures and bad batteries
- Includes a battery charge/discharge indication
- Choice of 3 display modes (volts only, current only, or dual current and voltage display)
- Records maximum volts, charge and discharge currents in permanent memory
- Analog bar graph indicating charge/discharge current
- Multi-language support
- Standard 2.25" aircraft enclosure (can be front or rear mounted)
- Rotary control plus 2 independent buttons for easy menu navigation and user input
- Alarm output as well as a red LED that illuminates when the alarm has been activated
- Large backlit graphic LCD with adjustable contrast
- On board voltage reversal and over voltage protection for harsh electrical environments
- SMPS (switch mode power supply) for use in both 12V and 24V systems as well as for reduced power consumption
- Light weight design
- 1 year limited warranty

2 BAT-1 Layout

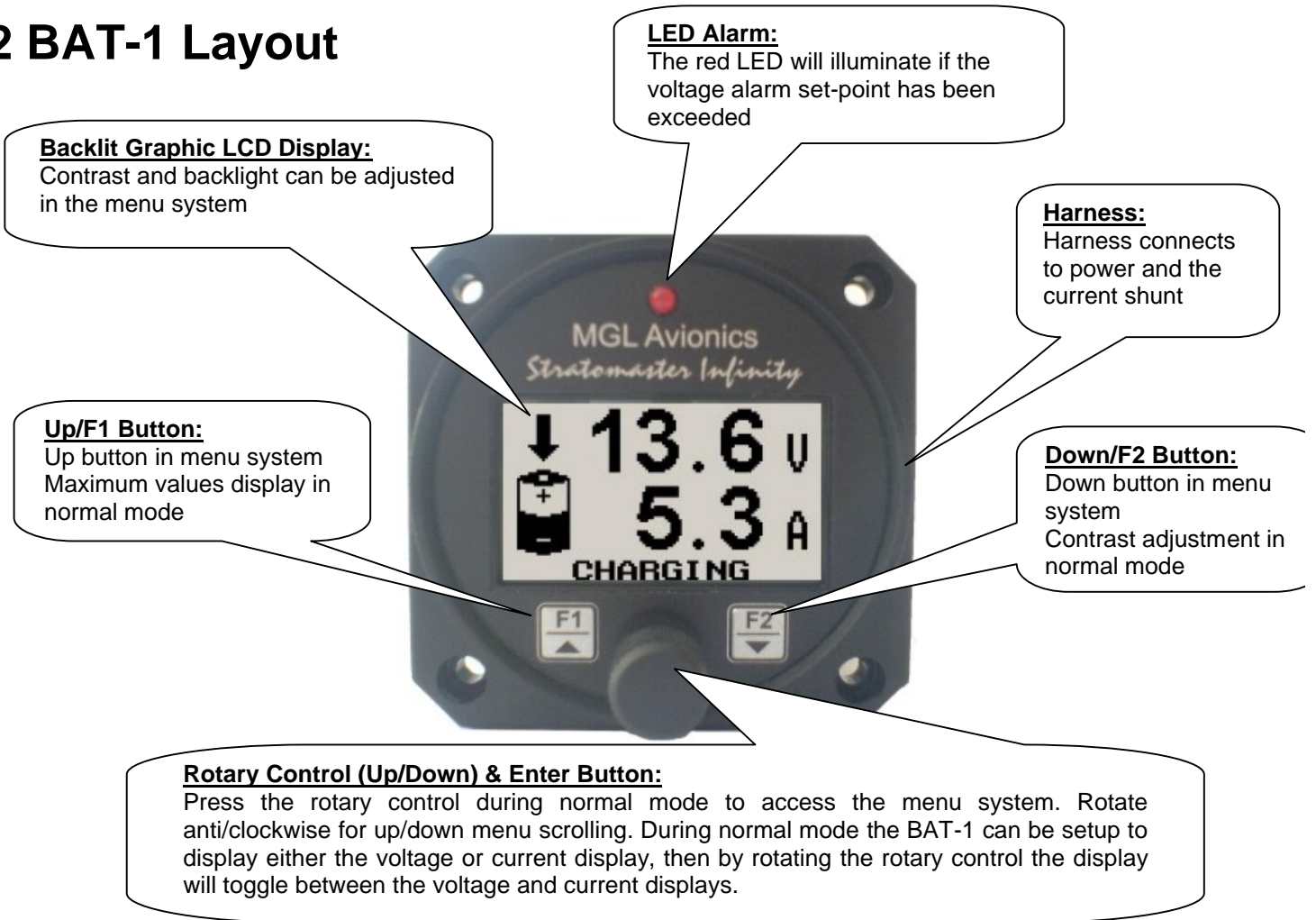

3 Main Display

There are 3 main displays that can be setup to be displayed on the BAT-1: dual mode (current and voltage), voltage display only or current display only. The unit can be setup to toggle manually or automatically between voltage and current in the single value display modes.

Dual Mode

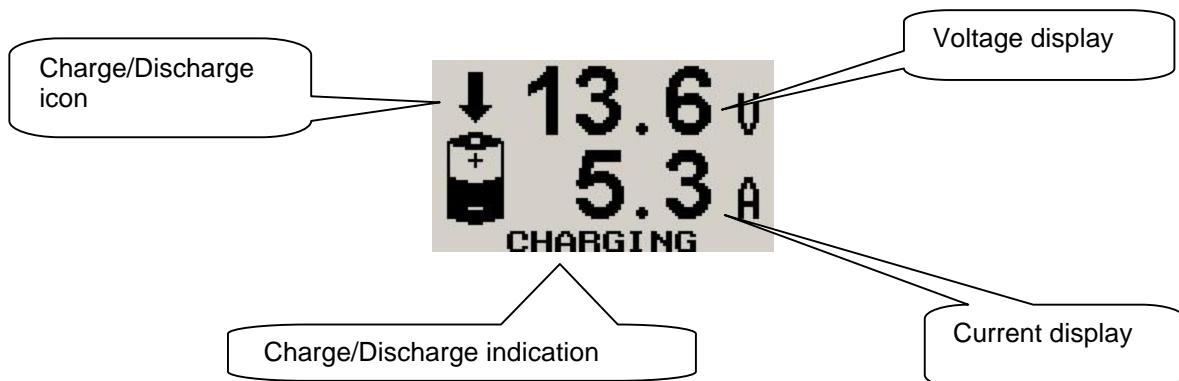

Voltage Only

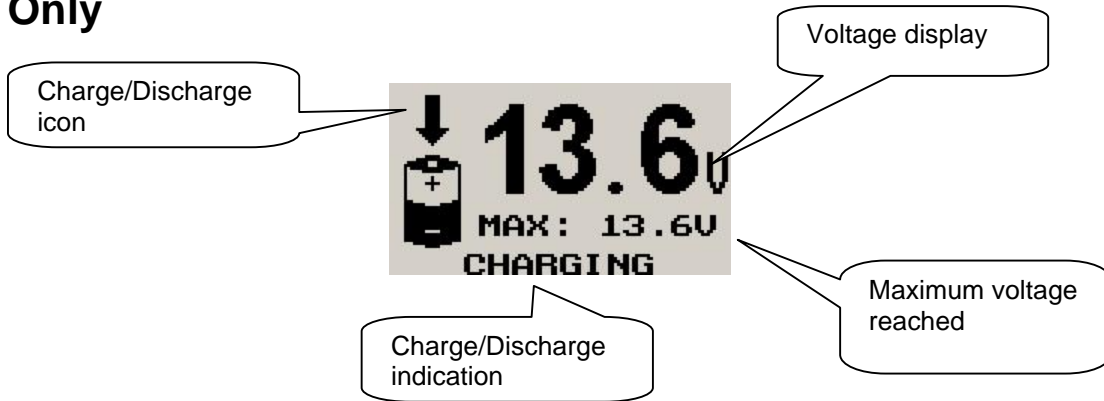

Current Only

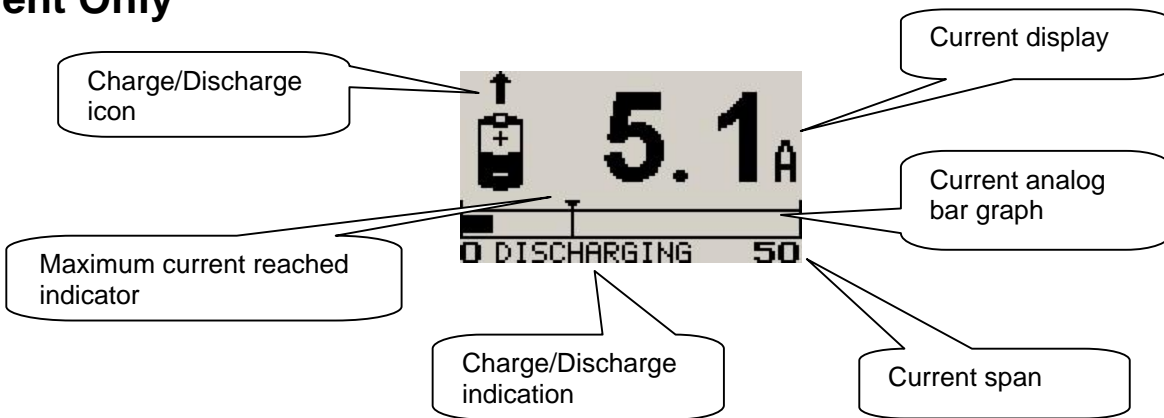

3.1 Contrast Display

This display can be accessed by pressing the F2 key during the normal display mode. This is a quick access key to the same contrast menu in the menu system.

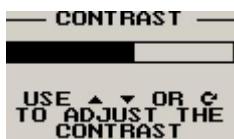

Select this menu option to adjust the display contrast

3.2 Maximum Values Display

This display can be accessed by pressing the F1 key during normal operation. Pressing the F1 key again will reset the maximum values to the current voltage and current values. Pressing any other key will cause the BAT-1 to return to the normal display mode. To avoid false recordings, the maximum values function is only activated 10 seconds after the instrument has powered up.

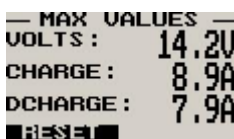

Note: The permanent maximum values are stored in non-volatile memory and are recalled on power-up.

4 Menu System

Pressing the rotary control button during the normal display mode will cause the BAT-1 to enter the menu system. Use the up/down keys or the rotary control to navigate through the menu system. If no key is pressed within 30 seconds, the BAT-1 will return to the normal display mode.

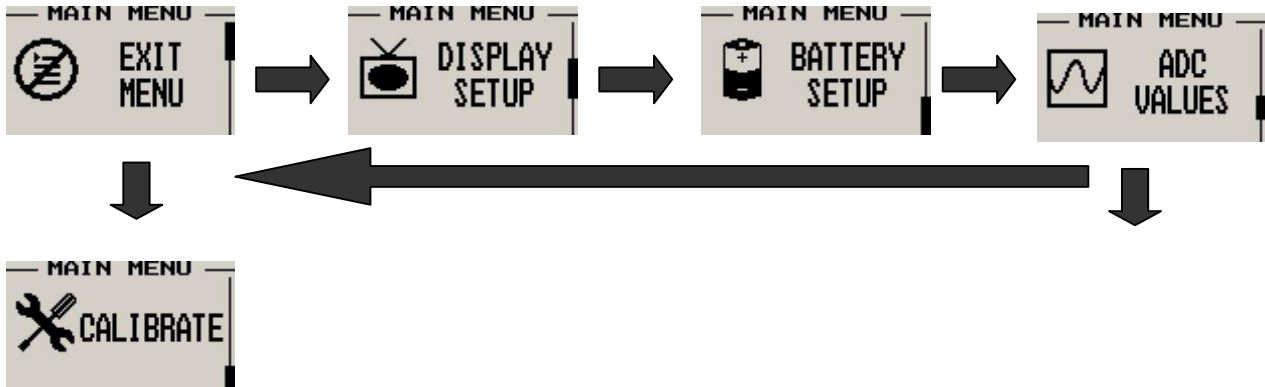

Note: (ADC Values and Calibrate Menus are only visible when powering up the unit and pressing the Rotary Control). The text "CALIBRATE" will appear on the intro screen when entering this mode.

Warning: The Calibrate Menu is for technical personnel only. Changing any values in this menu may cause the instrument to display incorrect information, and may require the instrument to be returned to the factory for recalibration.

4.1 Exit Menu



Pressing the rotary control on this menu item will cause the BAT-1 to exit the menu system. All changes made during navigation of the menu system will be saved in non-volatile memory on exiting the menu system. If you remove power before exiting the menu the instrument will not save any changes.

4.2 Display Setup

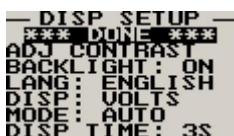

Move the highlight over the "DONE" menu item and press the rotary button to return to the main menu

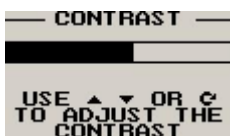
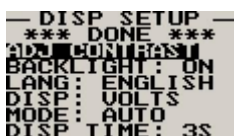

Select this menu option to adjust the display contrast

```

-- DISP SETUP --
*** DONE ***
ADJ CONTRAST
BACKLIGHT: ON
LANG: ENGLISH
DISP: VOLTS
MODE: AUTO
DISP TIME: 3S
    
```

Select this menu option to turn the backlight on and off

```

-- DISP SETUP --
*** DONE ***
ADJ CONTRAST
BACKLIGHT: ON
LANG: ENGLISH
DISP: VOLTS
MODE: AUTO
DISP TIME: 3S
    
```

Select your preferred language for the BAT-1.

```

-- DISP SETUP --
*** DONE ***
ADJ CONTRAST
BACKLIGHT: ON
LANG: ENGLISH
DISP: VOLTS
MODE: AUTO
DISP TIME: 3S
    
```

Select the display mode of the main display: dual mode, voltage only or current only

```

-- DISP SETUP --
*** DONE ***
ADJ CONTRAST
BACKLIGHT: ON
LANG: ENGLISH
DISP: VOLTS
MODE: AUTO
DISP TIME: 3S
    
```

Select whether you want the single voltage/current display to alternate automatically or manually
This display is only shown if display mode is setup to show either voltage only or current only

```

-- DISP SETUP --
*** DONE ***
ADJ CONTRAST
BACKLIGHT: ON
LANG: ENGLISH
DISP: VOLTS
MODE: AUTO
DISP TIME: 3S
    
```

Set the time that the single display modes must be displayed for. This display is only shown if auto is selected for the display mode

4.3 Battery Setup

```

-- MAIN MENU --
 BATTERY
SETUP
    
```

All the battery voltage and shunt parameters can be setup here

```

-- BAT SETUP --
*** DONE ***
SHUNT A: 50A
SHUNT mV: 50mV
BAR SCALE: 50A
VOLT ALM: ON
LOW ALM: 10.0V
HIGH ALM: 15.0V
    
```

Move the highlight over the "DONE" menu item and press the rotary button to return to the main menu

```

-- BAT SETUP --
*** DONE ***
SHUNT A: 50A
SHUNT mV: 50mV
BAR SCALE: 50A
VOLT ALM: ON
LOW ALM: 10.0V
HIGH ALM: 15.0V
    
```

Select the current capacity of your current shunt. The BAT-1 can use current shunts in the range of 5A to 500A.

```

-- BAT SETUP --
*** DONE ***
SHUNT A: 50A
SHUNT mV: 50mV
BAR SCALE: 50A
VOLT ALM: ON
LOW ALM: 10.0V
HIGH ALM: 15.0V
    
```

Select the mV rating of your current shunt. Current shunts in the range from 50mV to 100mV can be used.

```

-- BAT SETUP --
*** DONE ***
SHUNT A: 50A
SHUNT mV: 50mV
BAR SCALE: 50A
VOLT ALM: ON
LOW ALM: 10.0V
HIGH ALM: 15.0V
    
```

Select the maximum value that you want the current analog bar graph display to show, i.e. your current shunt may be a 50A 50mV shunt but the maximum current that you will ever measure is only 7A, then you can scale the bar graph to show a maximum value of 10A. This gives you increased display resolution

```

-- BAT SETUP --
*** DONE ***
SHUNT A: 50A
SHUNT mV: 50mV
BAR SCALE: 50A
VOLT ALM: ON
LOW ALM: 10.0V
HIGH ALM: 15.0V
    
```

Select whether you want the voltage alarm to be turned on or off. To avoid false activation of the alarms, the alarm function is only activated 10 seconds after the instrument has powered up



Enter the low voltage set-point for when the alarm must be activated. Any voltage below this value will activate the alarm



Enter the high voltage set-point for when the alarm must be activated. Any voltage above this value will activate the alarm

4.4 ADC Values



Note: This menu item is for technical personnel only, and is not displayed during the normal operation of the instrument. Please see section 4 above on how to access this menu item



This menu displays the ADC values that have been read from the voltage and current circuits

4.5 Calibrate



Note: This menu item is for technical personnel only, and is not displayed during the normal operation of the instrument. Please see section 4 above on how to access this menu item. Consult your local dealer or factory before entering this menu.

5 Loading Factory default settings

Pressing and holding the F1 and F2 keys simultaneously on power up will cause the BAT-1 to load preprogrammed factory default settings. The following screen will be displayed:



6 Operating the alarms

If the alarm is activated, the corresponding item on the display will flash. At the same time the externally available alarm switch will close. The switch will remain closed until any button is pressed to acknowledge the alarm or until the condition(s) that activated the alarm no longer exist. The alarm output can be used to switch an external alarm indicator. The external alarm switch is an open collector transistor switch to ground with a maximum rating of 0.5A DC. It is possible to wire the alarm contacts of several Stratomaster Infinity instruments in parallel should this be desired. To avoid false activation of the alarms, the alarm function is only active 10 seconds after the instrument has powered up.

7 Shunt selection

The BAT-1 can use a current shunt in the range from 5A to 500A, 50mV to 100mV. Please note that the current shunt rating can effect resolution and accuracy of the BAT-1. Select a current shunt that is right for your application. Try use a current shunt that is close to the current range you are measuring.

The BAT-1 measures current by measuring the voltage drop across the current shunt. The BAT-1 is calibrated for +-100mV. Try to use a current shunt mV rating close to this value to increase the measurement resolution. The BAT-1 has a resolution of 0.1A up to 10A and 1A from 10A to 500A. If the current shunt selected is above 100A then the resolution is fixed at 1A. The BAT-1 has an over range warning if you exceed the current rating of the shunt by +-10%.

8 Cleaning

The unit should not be cleaned with any abrasive substances. The screen is very sensitive to certain cleaning materials and should only be cleaned using a clean, damp cloth.

Warning: The BAT-1 is not waterproof. Serious damage could occur if the unit is exposed to water and/or spray jets.

9 BAT-1 Specifications

Operating Temperature Range	-10°C to 50°C (14°F to 122°F)
Storage Temperature Range	-20°C to 80°C (-4°F to 176°F)
Humidity	<85% non-condensing
Power Supply	8 to 30Vdc SMPS (switch mode power supply) with built in 33V over voltage and reverse voltage protection
Current Consumption	Approx. 30mA @ 13.8V (backlight on) 15mA @13.8V (backlight off)
Display	114x64 graphics LCD display. Contrast and backlight is user configurable, green/yellow backlight
ADC	12bit over sampled successive approximation
Dimensions	60mmx60mmx61mm (2.36"x2.36"x2.40") (see Infinity series dimensional drawing)
Enclosure	2.25" ABS, black in color, front or rear mounting
Weight	Approx. 85 grams
Alarm contact current rating	Open collector transistor switch to ground. Maximum rating 0.5A DC
Non-volatile memory storage	100000 write cycles
Current shunts supported	50mV to 100mV, 5A to 500A
Current resolution	0.1A from 0 to +-10A (Current shunt<=100A), 1A above 10A
Voltage resolution	0.1V

10 Installation

Make sure that the starter motor does not go through the shunt resistor. This will cause excessive current to be drawn and can result in damage to the shunt. Also check that the cable from the alternator is going through the shunt, so that charging current can be measured.

10.1 Connection Diagram

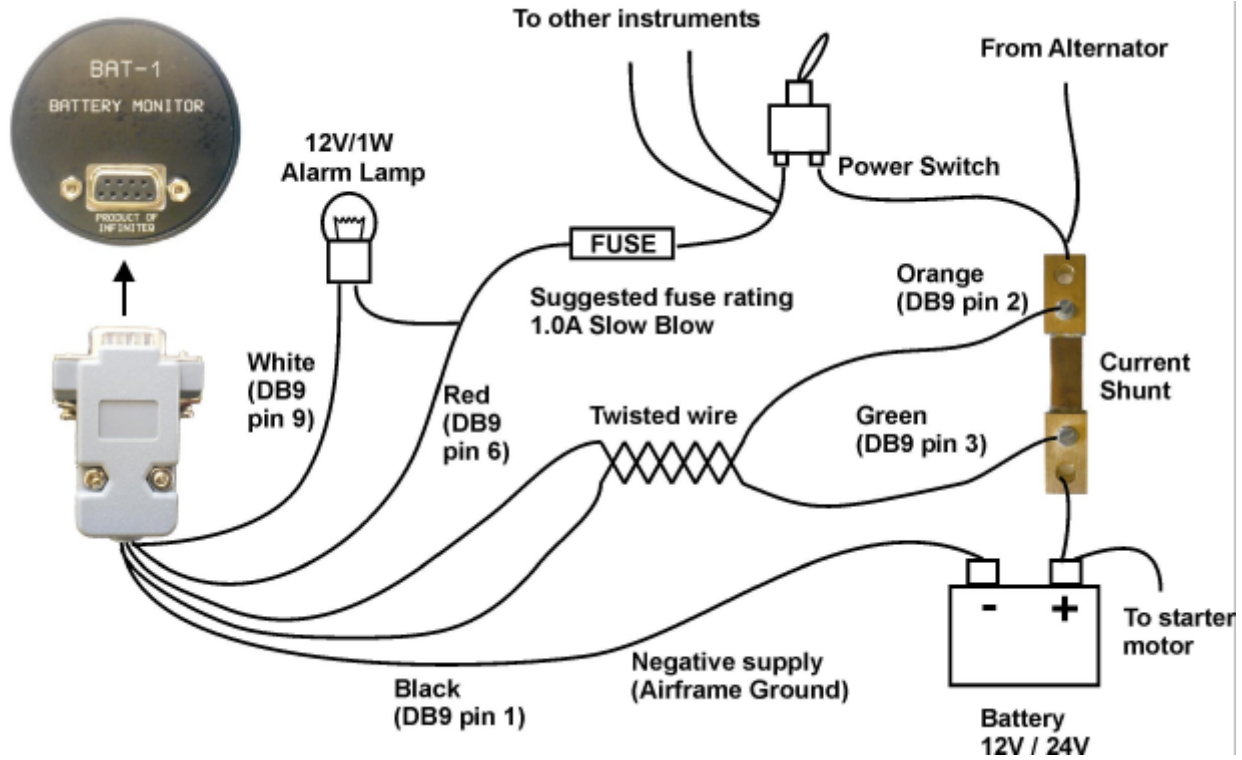

The use of an external 1A fuse is recommended. Connect the supply terminals to your aircrafts power supply. The BAT-1 can be used on both 12V and 24V without the use of any pre-regulators. Ensure that the supply voltage will not drop below 8V during operation as this may result in incorrect voltage and/or current readings.

10.2 BAT-1 DB9 Cable connections

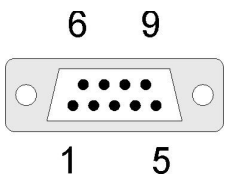

DB 9 Pin	Color	Function
1	Black	Ground
2	Orange	Shunt -
3	Green	Shunt +
4	NC	Airtalk communication (Not connected) Used for firmware upgrading
6	Red	8-30Vdc power
9	White	Alarm Output

11 Warranty

This product carries a warranty for a period of one year from date of purchase against faulty workmanship or defective materials, provided there is no evidence that the unit has been mishandled or misused. Warranty is limited to the replacement of faulty components and includes the cost of labour. Shipping costs are for the account of the purchaser.

Note: Product warranty excludes damages caused by unprotected, unsuitable or incorrectly wired electrical supplies and/or sensors, and damage caused by inductive loads.

12 Disclaimer

Operation of this instrument is the sole responsibility of the purchaser of the unit. The user must make themselves familiar with the operation of this instrument and the effect of any possible failure or malfunction.

This instrument is not certified by the FAA. Fitting of this instrument to certified aircraft is subject to the rules and conditions pertaining to such in your country. Please check with your local aviation authorities if in doubt. This instrument is intended for ultralight, microlight, homebuilt and experimental aircraft. Operation of this instrument is the sole responsibility of the pilot in command (PIC) of the aircraft. This person must be proficient and carry a valid and relevant pilot's license. This person has to make themselves familiar with the operation of this instrument and the effect of any possible failure or malfunction. Under no circumstances does the manufacturer condone usage of this instrument for IFR flights.

The manufacturer reserves the right to alter any specification without notice.

Other instruments in the Stratomaster Infinity series

ALT-1	Precision encoding altimeter and vertical speed indicator
ASI-1	Airspeed indicator (ASI) with automatic flight log
ASX-1	Encoding aviation altimeter with serial output and airspeed indicator (ASI)
AV-1	Artificial horizon and magnetic compass indicator
BAT-1	Battery voltage and current monitor
E-3	Universal engine monitor
FF-1	Fuel computer (single or dual fuel tanks)
GF-1	+/-10G tilt compensated dual range G-force meter
MAP-1	Universal pressure indicator
RV-1	Universal engine RPM and rotor RPM Indicator
RTC-2	Aviation real time clock (RTC) and outside air temperature (OAT) display
TC-1	4-Channel thermocouple indicator
TP-1	Universal temperature and pressure gauge