

# TP-1

## Universal Temperature / Pressure Gauge

Operating Manual – English 1.00



## Introduction

The TP-1 is a 2.25" universal temperature/pressure gauge which can be setup to display oil temperature, coolant temperature, oil pressure, fuel pressure, manifold pressure and boost pressure.

The TP-1 gauge can be programmed by the user for a variety of temperature/pressure ranges and can be adapted to many types of senders. Temperature can be measured using standard automotive NTC senders as well as the MGL Avionics semiconductor sensor. Pressure can be measured using standard VDO automotive senders as well as linear pressure transducers.

Both the temperature and pressure readings have a programmable low and high alarm. This results in a contact closure that is typically used to switch a warning lamp on. The TP-1 also records the maximum temperature and pressure values reached in permanent memory.

## 1 Features

- Universal temperature and pressure gauge
- Uses standard automotive temperature and pressure senders
- Both temperature and pressure readings have a programmable low and high alarm
- Records maximum temperature and pressure reached in permanent memory
- Standard 2.25" aircraft enclosure (can be front or rear mounted)
- Rotary control plus 2 independent buttons for easy menu navigation and user input
- External alarm output as well as a red LED illuminates when the alarm has been activated
- Large backlit graphic LCD with adjustable contrast
- On board voltage reversal and over voltage protection for harsh electrical environments
- SMPS (switch mode power supply) for use in both 12V and 24V systems as well as for reduced power consumption
- Light weight design
- 1 year limited warranty

## 2 TP-1 Layout

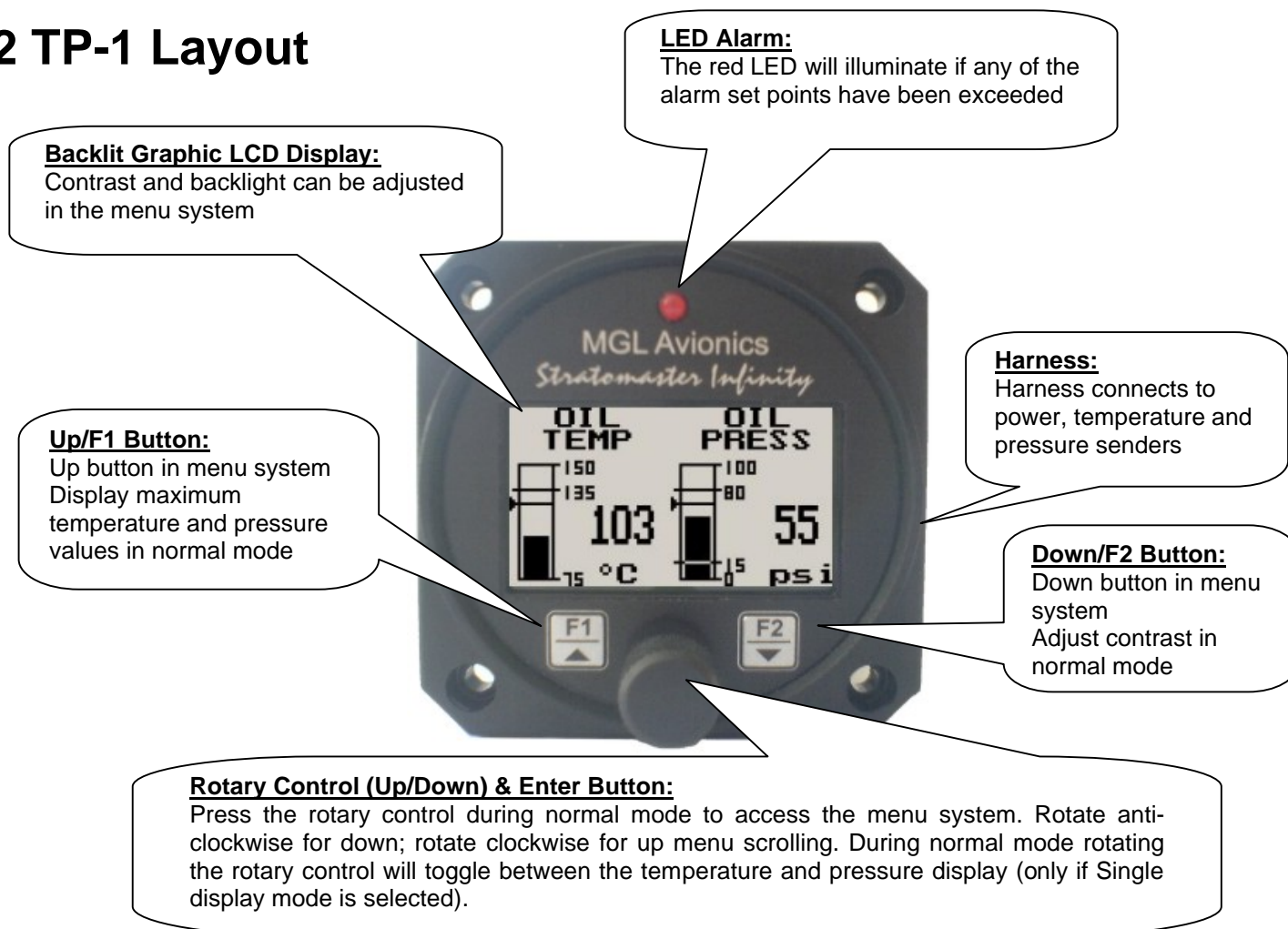

## 3 Main Display

The TP-1 has 4 different temperature/pressure display screens. These screens can be setup under the "DISPLAY SETUP" menu option. The display can be setup to display pressure and temperature as vertical or horizontal bar graphs as well as dual or single displays. If the TP-1 is setup to display single values then rotating the rotary control will toggle between the temperature and pressure displays.

### Display Mode 1: Dual/Vertical mode

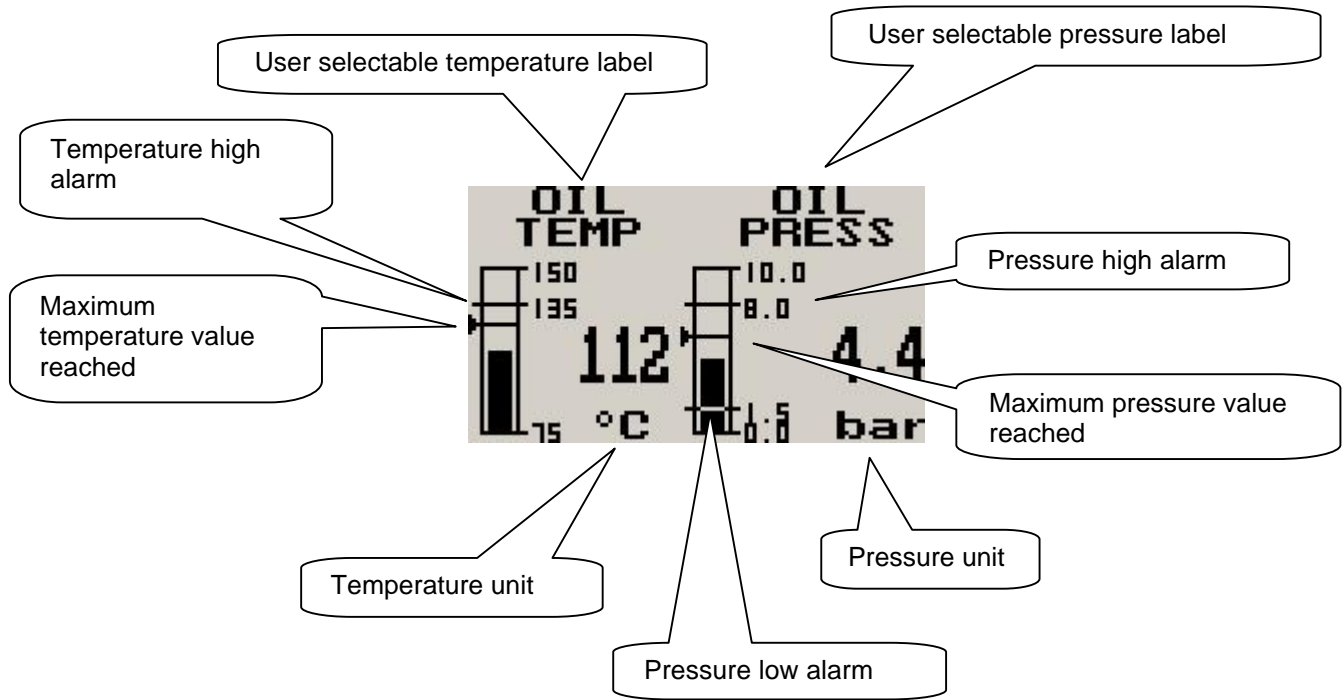

### Display Mode 2: Dual/Horizontal mode

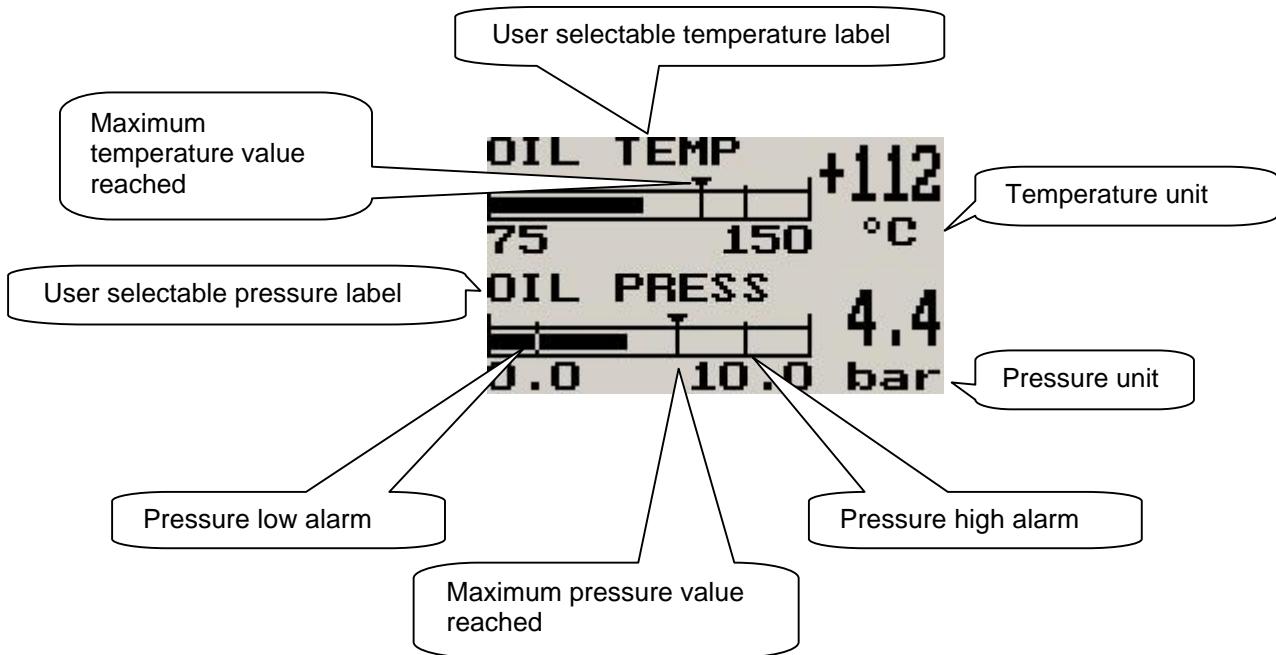

### Display Mode 3: Single/Vertical mode

You can toggle between temperature and pressure by rotating the rotary control.

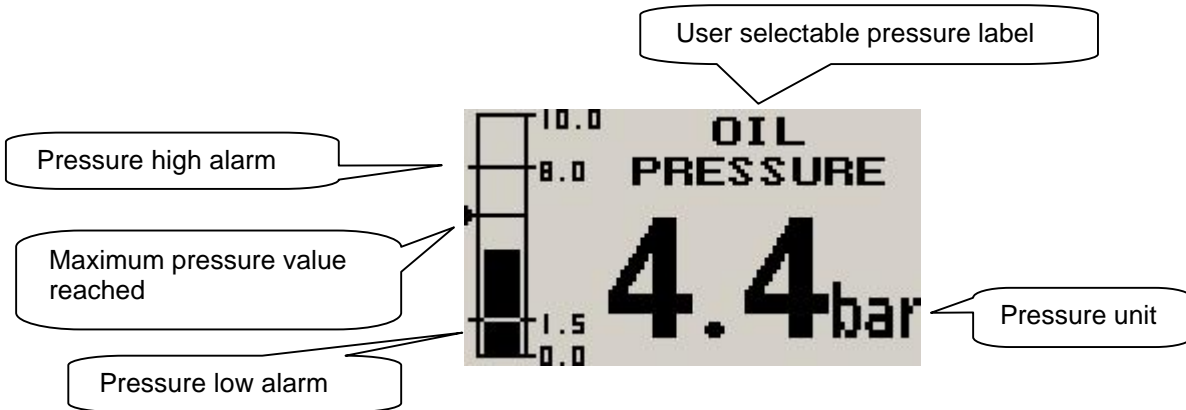
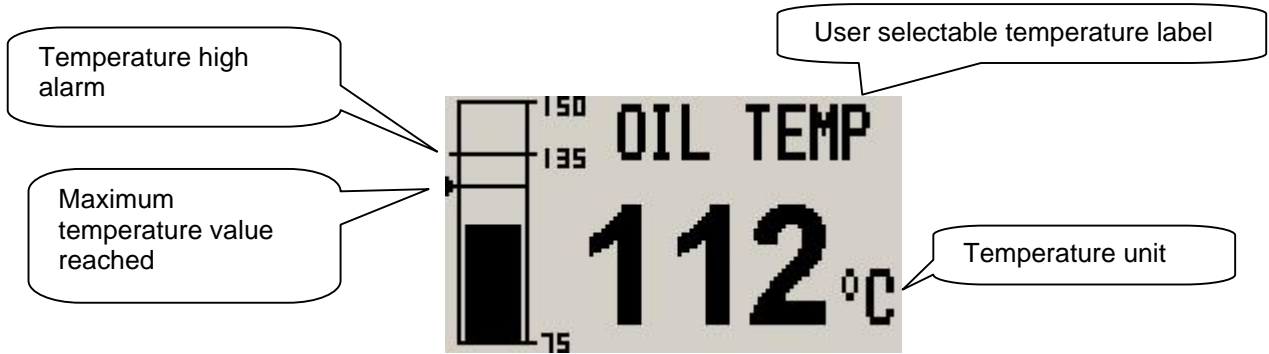

### Display Mode 4: Single/Horizontal mode

You can toggle between temperature and pressure by rotating the rotary control.

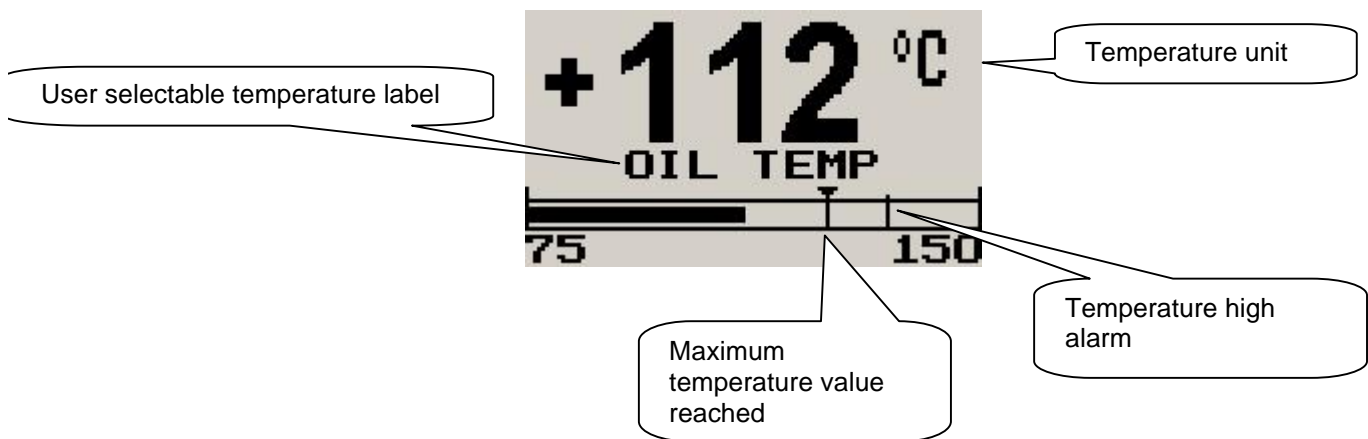

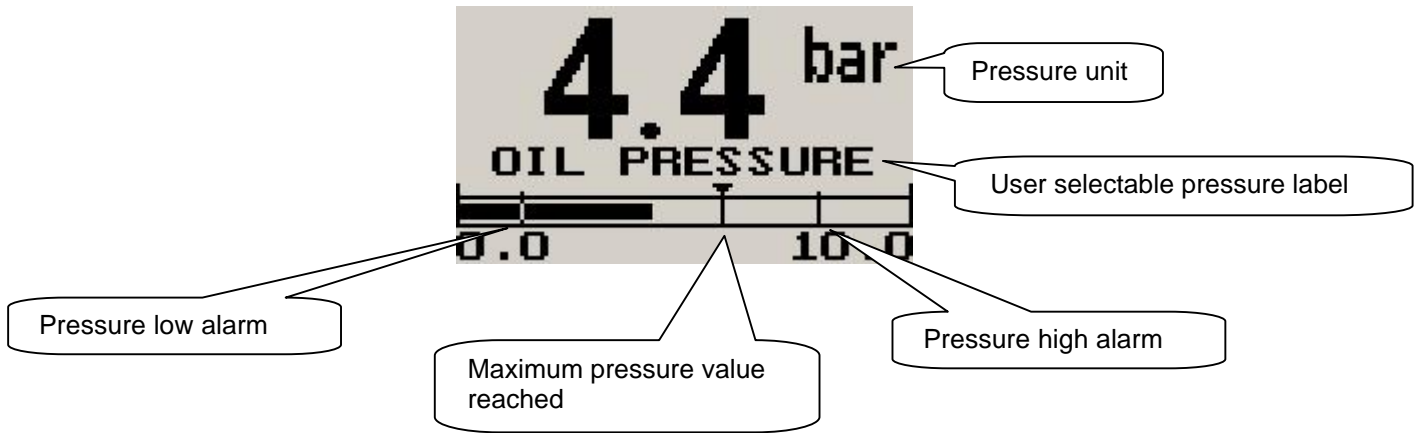

### 3.1 Permanent maximum values display

This display can be accessed by pressing the F1 key during the normal display mode. Pressing the F1 key again will reset the permanent maximum values to the current temperature and pressure values. Pressing any other key will cause the TP-1 to return to the normal display mode. To avoid false recordings, the maximum values function is only activated 10 seconds after the instrument has powered up.



**Note:** The permanent maximum values are stored in non-volatile memory and are recalled on power-up.

### 3.2 Contrast display

This display can be accessed by pressing the F2 key during the normal display mode. This is a quick access key to the same contrast menu as in the menu system.

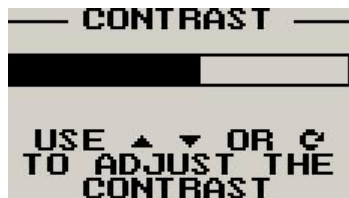

Use the up and down keys or the rotary control to adjust the display contrast.

## 4 Menu System

Pressing the rotary control button during the normal display mode will cause the TP-1 to enter the menu system. Use the up/down keys or the rotary control to navigate through the menu system. If no key is pressed within 30 seconds, the TP-1 will return to the normal display mode.

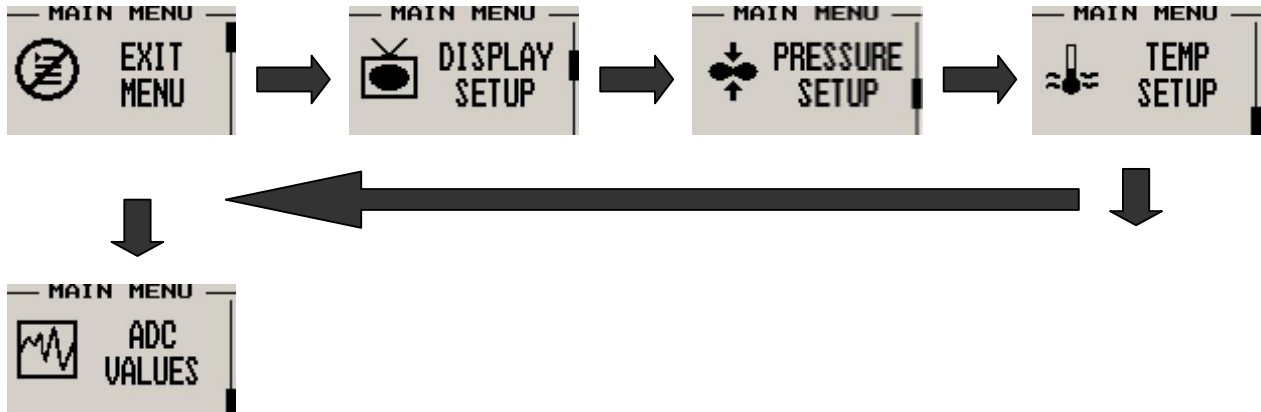

**Note:** “ADC Values” menu item is only visible when switching the unit on and pressing the rotary control. The text “CALIBRATE” will appear on the intro screen when entering this mode.

### 4.1 Exit Menu



Pressing the rotary control on this menu item will cause the TP-1 to exit the menu system. All changes made during navigation of the menu system will be saved in non-volatile memory on exiting the menu system. If you remove power before exiting the menu the instrument will not save any changes.

### 4.3 Display Setup



Move the highlight over this menu item and press the rotary button to return to the main menu.

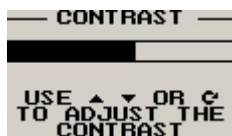
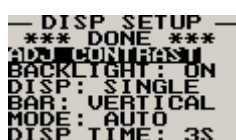

Select this menu option to adjust the display contrast.

```

- DISP SETUP -
*** DONE ***
ADJ CONTRAST
BACKLIGHT: ON
DISP: SINGLE
BAR: VERTICAL
MODE: AUTO
DISP TIME: 3S
    
```

Select this menu option to turn the backlight on or off.

```

- DISP SETUP -
*** DONE ***
ADJ CONTRAST
BACKLIGHT: ON
DISP: DUAL
BAR: VERTICAL
MODE: AUTO
DISP TIME: 3S
    
```

If "SINGLE" is selected then only temperature or pressure is shown at one time. If "DUAL" is selected then both temperature and pressure are shown on the same screen.

```

- DISP SETUP -
*** DONE ***
ADJ CONTRAST
BACKLIGHT: ON
DISP: SINGLE
BAR: HORIZONTAL
MODE: AUTO
DISP TIME: 3S
    
```

Select whether you want the temperature and pressure bar to be shown vertically or horizontally.

```

- DISP SETUP -
*** DONE ***
ADJ CONTRAST
BACKLIGHT: ON
DISP: SINGLE
MODE: MANUAL
DISP TIME: 3S
    
```

Select whether you want the single temperature/pressure display to alternate automatically or manually. This display is only shown if display mode is setup to show "SINGLE".

```

- DISP SETUP -
*** DONE ***
ADJ CONTRAST
BACKLIGHT: ON
DISP: SINGLE
MODE: AUTO
DISP TIME: 3S
    
```

Set the time that the single display modes must be displayed for. This display is only shown if auto is selected for the display mode.

## 4.4 Pressure Setup

```

- MAIN MENU -
↓
PRESSURE
↑
SETUP
    
```

The pressure setup menu item allows the user to adjust the pressure sender properties.

```

- PRESS SETUP -
*** DONE ***
LABEL: OIL
SPAN: 10.0 BAR
TOPSCALE: OFF
ALM LOW: ON
ALM LOW: 1.5
ALM HIGH: ON
    
```

Move the highlight over this menu item and press the rotary button to return to the main menu.

```

- PRESS SETUP -
*** DONE ***
LABEL: OIL
SPAN: 10.0 BAR
TOPSCALE: OFF
ALM LOW: ON
ALM LOW: 1.5
ALM HIGH: ON
    
```

Choose one of a selection of labels to suit your pressure input so you can identify it easily.

```

- PRESS SETUP -
*** DONE ***
LABEL: OIL
SPAN: 10.0 BAR
TOPSCALE: OFF
ALM LOW: ON
ALM LOW: 1.5
ALM HIGH: ON
    
```

Set the range of the pressure sender. The range can be set from 1 Bar to 10 Bar.

```

- PRESS SETUP -
*** DONE ***
LABEL: OIL
SPAN: 10.0 BAR
TOPSCALE: ON
ALM LOW: ON
ALM LOW: 1.5
ALM HIGH: ON
    
```

This allows the user to zoom into the top half of the bar graph resulting in a higher display resolution. This option set to "ON" is recommended.

```

- PRESS SETUP -
*** DONE ***
LABEL: OIL
SPAN: 10.0 BAR
TOPSCALE: OFF
ALM LOW: ON
ALM LOW: 1.5
ALM HIGH: ON
    
```

Select whether to use the low pressure alarm.

```

- PRESS SETUP -
*** DONE ***
LABEL: OIL
SPAN: 10.0 BAR
TOPSCALE: OFF
ALM LOW: ON
ALM HIGH: ON
    
```

Use this to set the low pressure alarm set-point.

```

- PRESS SETUP -
*** DONE ***
LABEL: OIL
SPAN: 10.0 BAR
TOPSCALE: OFF
ALM LOW: ON
ALM LOW: 1.5
ALM HIGH: ON
    
```

Select whether to use the high pressure alarm.

```

- PRESS SETUP -
LABEL: OIL
SPAN: 10.0 BAR
TOPSCALE: OFF
ALM LOW: ON
ALM LOW: 1.5
ALM HIGH: ON
ALM HIGH: 8.0
    
```

Use this to set the high pressure alarm set-point.

```

- PRESS SETUP -
SPAN: 10.0 BAR
TOPSCALE: OFF
ALM LOW: ON
ALM LOW: 1.5
ALM HIGH: ON
ALM HIGH: 8.0
MAX RES: 180Ω
    
```

Enter the maximum resistance of your pressure sender. Common VDO pressure senders are typically 180 Ohms.

```

- PRESS SETUP -
TOPSCALE: OFF
ALM LOW: ON
ALM LOW: 1.5
ALM HIGH: ON
ALM HIGH: 8.0
MAX RES: 180Ω
MAX PRESS: 10.0
    
```

Enter the maximum pressure for your pressure sender. If you are using a VDO 10 bar pressure sender then enter in 10.0, if you are using a VDO 5 bar, then enter in 5.0, if you are using a VDO 2 bar then enter in 2.0.

```

- PRESS SETUP -
ALM LOW: ON
ALM LOW: 1.5
ALM HIGH: ON
ALM HIGH: 8.0
MAX RES: 180Ω
MAX PRESS: 10.0
SENDER DIR: INC
SENDER: VDO
    
```

Select whether your pressure sender increases resistance with pressure or decreases resistance with pressure. VDO senders normally increase resistance with pressure.

```

- PRESS SETUP -
ALM LOW: 1.5
ALM HIGH: ON
ALM HIGH: 8.0
MAX RES: 180Ω
MAX PRESS: 10.0
SENDER DIR: INC
UNIT: BAR
    
```

Select whether you want to display the pressure in Bar or PSI.

```

- PRESS SETUP -
ALM HIGH: ON
ALM HIGH: 8.0
MAX RES: 180Ω
MAX PRESS: 10.0
SENDER DIR: INC
UNIT: BAR
SENDER: VDO
    
```

Select what sender type you are using. Select VDO for VDO pressure senders, "USER" for a custom sender.

```

- PRESS SETUP -
ALM HIGH: 8.0
MAX RES: 180Ω
MAX PRESS: 10.0
SENDER DIR: INC
UNIT: BAR
SENDER: USER
SENDER: USER
    
```

```

- PRESS: 462 -
*** DONE ***
POINTS: 10
DISPLAY 1: 1.0
ADC 1: 1000
DISPLAY 2: 2.0
ADC 2: 0900
DISPLAY 3: 3.0
    
```

If the sender type is set to "USER", then use this menu option to calibrate your pressure sender.

## 4.5 Temperature Setup

```

- MAIN MENU -
TEMP
SETUP
    
```

The temperature setup menu item allows the user to adjust the temperature sender properties.

```

- TEMP SETUP -
*** DONE ***
LABEL: OIL
SPAN: 150°C
TOPSCALE: ON
ALARM LOW: ON
ALARM LOW: 70
ALARM HIGH: ON
    
```

Move the highlight over this menu item and press the rotary button to return to the main menu.

```

-- TEMP SETUP --
*** DONE ***
LABEL: OIL
SPAN: 150°C
TOPSCALE: ON
ALARM LOW: ON
ALARM LOW: 70
ALARM HIGH: ON
    
```

Choose one of a selection of labels to suit your temperature input so you can identify it easily.

```

-- TEMP SETUP --
*** DONE ***
LABEL: OIL
SPAN: 150°C
TOPSCALE: ON
ALARM LOW: ON
ALARM LOW: 70
ALARM HIGH: ON
    
```

Set the range of the temperature sender. The range can be set from 20°C to 180°C.

```

-- TEMP SETUP --
*** DONE ***
LABEL: OIL
SPAN: 150°C
TOPSCALE: ON
ALARM LOW: ON
ALARM LOW: 70
ALARM HIGH: ON
    
```

This allows the user to zoom into the top half of the bar graph resulting in a higher display resolution. This option set to "ON" is recommended.

```

-- TEMP SETUP --
*** DONE ***
LABEL: OIL
SPAN: 150°C
TOPSCALE: ON
ALARM LOW: ON
ALARM LOW: 70
ALARM HIGH: ON
    
```

Select whether to use the low temperature alarm.

```

-- TEMP SETUP --
*** DONE ***
LABEL: OIL
SPAN: 150°C
TOPSCALE: ON
ALARM LOW: ON
ALARM LOW: 70
ALARM HIGH: ON
    
```

Use this to set the low temperature alarm set-point.

```

-- TEMP SETUP --
*** DONE ***
LABEL: OIL
SPAN: 150°C
TOPSCALE: ON
ALARM LOW: ON
ALARM LOW: 70
ALARM HIGH: ON
    
```

Select whether to use the high temperature alarm.

```

-- TEMP SETUP --
*** DONE ***
LABEL: OIL
SPAN: 150°C
TOPSCALE: ON
ALARM LOW: ON
ALARM LOW: 70
ALARM HIGH: ON
    
```

Use this to set the high temperature alarm set-point.

```

-- TEMP SETUP --
*** DONE ***
SPAN: 150°C
TOPSCALE: ON
ALARM LOW: ON
ALARM LOW: 70
ALARM HIGH: ON
ALARM HIGH: 135
UNIT: °C
    
```

Select whether you want the temperature to be displayed in degrees Celcius (°C) or in degrees Fahrenheit (°F).

```

-- TEMP SETUP --
*** DONE ***
TOPSCALE: ON
ALARM LOW: ON
ALARM LOW: 70
ALARM HIGH: ON
ALARM HIGH: 135
UNIT: °C
SENDER: USER
    
```

Select what sender type you are using. Select VDO for VDO senders/LM335 for the MGL precision temperature sender or "USER" for a custom sender. The TP-1 has a built in linearization curve for a VDO 323-801-009-001D temperature sender.

```

-- TEMP SETUP --
*** DONE ***
ALARM LOW: ON
ALARM LOW: 70
ALARM HIGH: ON
ALARM HIGH: 135
UNIT: °C
SENDER: USER
    
```

```

-- TEMP: 969 --
*** DONE ***
POINTS: 10
DISPLAY 1: 010
ADC 1: 1000
DISPLAY 2: 020
ADC 2: 0900
DISPLAY 3: 030
    
```

If the sender type is set to "USER", then use this menu option to calibrate your temperature sender.

```

-- TEMP SETUP --
*** DONE ***
TOPSCALE: ON
ALARM LOW: ON
ALARM LOW: 70
ALARM HIGH: ON
ALARM HIGH: 135
UNIT: °C
SENDER: LM335
    
```

```

-- TEMP SETUP --
*** DONE ***
ALARM LOW: ON
ALARM LOW: 70
ALARM HIGH: ON
ALARM HIGH: 135
UNIT: °C
SENDER: LM335
LM335: 10 29°C
    
```

If the sender type is set to LM335, then use this menu option to calibrate your LM335 precision temperature sender. If recalibration is required then adjust the value using the up/down keys or the rotary control until the temperature matches the reference ambient temperature. Please note that the LM335 can only be calibrated in degrees Celcius irrespective if the TP-1 is setup to Fahrenheit.

## Calibrating the user defined pressure and temperature sender

```

-- PRESS : 462
*** DUNE ***
POINTS : 10
DISPLAY 1:1.0
ADC 1 : 1000
DISPLAY 2:2.0
ADC 2 : 0900
DISPLAY 3:3.0

```

```

-- TEMP : 969
*** DUNE ***
POINTS : 10
DISPLAY 1:010
ADC 1 : 1000
DISPLAY 2:020
ADC 2 : 0900
DISPLAY 3:030

```

1. Enter the number of points that you want to calibrate.
2. Enter the display reading that you want to show when the sender is at that actual display reading.
3. Enter the ADC (analog to digital converter) reading that corresponds to this display reading. The ADC reading is shown at the top of the calibration menu if you are applying the actual stimulus from the temperature or pressure sender. You can also manually enter this value if the ADC value is known or pre-calculated.
4. Continue entering display and ADC values until all the points have been entered.
5. Verify the above calibration by checking the temperature/pressure display versus the actual applied sender stimulus.

## 4.6 ADC Values

```

-- MAIN MENU
[Waveform Icon] ADC
VALUES

```

**Note:** This menu item is for technical personnel only, and is not displayed during the normal operation of the instrument. Please see section 4 above on how to access this menu item.

```

-- ADC VALUES
*** DUNE ***
PRESSURE : 1608
TEMP : 1299

```

This menu displays the ADC values that have been read from the temperature and pressure senders.

## 5 Loading Factory default settings

Pressing and holding the F1 and F2 keys simultaneously on power up will cause the TP-1 to load preprogrammed factory default settings. The following screen will be displayed:

```

LOADING
DEFAULT
SETTINGS

```

## 6 Operating the alarms

If the alarm is activated, the corresponding item on the display will flash. At the same time the externally available alarm switch will close. The switch will remain closed until any button is pressed to acknowledge the alarm or until the condition(s) that activated the alarm no longer exist. The alarm output can be used to switch an external alarm indicator. The external alarm switch is an open collector transistor switch to ground with a maximum rating of 0.5A DC. It is possible to wire the alarm contacts of several Stratomaster Infinity instruments in parallel should this be desired. To avoid false activation of the alarms, the alarm function is only active 10 seconds after the instrument has powered up.

## 7 Cleaning

The unit should not be cleaned with any abrasive substances. The screen is very sensitive to certain cleaning materials and should only be cleaned using a clean, damp cloth.

**Warning:** The TP-1 is not waterproof. Serious damage could occur if the unit is exposed to water and/or spray jets.

## 8 TP-1 Specifications

| <b>Operating Temperature Range</b>  | -10°C to 50°C (14°F to 122°F)  |                |                   |   |     |     |      |   |      |     |      |   |      |   |      |   |      |   |       |
|-------------------------------------|--|----------------|-------------------|---|-----|-----|------|---|------|-----|------|---|------|---|------|---|------|---|-------|
| <b>Storage Temperature Range</b>    | -20°C to 80°C (-4°F to 176°F)  |                |                   |   |     |     |      |   |      |     |      |   |      |   |      |   |      |   |       |
| <b>Humidity</b>                     | <85% non-condensing  |                |                   |   |     |     |      |   |      |     |      |   |      |   |      |   |      |   |       |
| <b>Power Supply</b>                 | 8 to 30Vdc SMPS (switch mode power supply) with built in 33V over voltage and reverse voltage protection   |                |                   |   |     |     |      |   |      |     |      |   |      |   |      |   |      |   |       |
| <b>Current Consumption</b>          | Approx. 30mA @ 13.8V (backlight on) 15mA @13.8V (backlight off)  |                |                   |   |     |     |      |   |      |     |      |   |      |   |      |   |      |   |       |
| <b>Display</b>                      | 114x64 graphic LCD display. Contrast and backlight is user configurable, green/yellow backlight  |                |                   |   |     |     |      |   |      |     |      |   |      |   |      |   |      |   |       |
| <b>ADC</b>                          | 12bit over sampled successive approximation  |                |                   |   |     |     |      |   |      |     |      |   |      |   |      |   |      |   |       |
| <b>Dimensions</b>                   | 60mmx60mmx61mm (2.36"x2.36"x2.40") (see Infinity series dimensional drawing)   |                |                   |   |     |     |      |   |      |     |      |   |      |   |      |   |      |   |       |
| <b>Enclosure</b>                    | 2.25" ABS, black in color, front or rear mounting  |                |                   |   |     |     |      |   |      |     |      |   |      |   |      |   |      |   |       |
| <b>Weight</b>                       | Approx. 80 grams   |                |                   |   |     |     |      |   |      |     |      |   |      |   |      |   |      |   |       |
| <b>Alarm contact current rating</b> | Open collector transistor switch to ground. Maximum rating 0.5A DC   |                |                   |   |     |     |      |   |      |     |      |   |      |   |      |   |      |   |       |
| <b>Non-volatile memory storage</b>  | 100000 write cycles  |                |                   |   |     |     |      |   |      |     |      |   |      |   |      |   |      |   |       |
| <b>Temperature sensors</b>          | MGL NTC Water temperature: 900 Ohms at 20 degrees C and 93 ohms at 85 degrees C<br>MGL Precision semiconductor: based on National Semiconductor LM335<br>Oil temperature: Resistance of 1000 ohms at 20 degrees C and 100 ohms at 85 degrees C (fitted as standard to Rotax 912/914 engines)<br>User defined senders: TP-1 has a sender calibration feature  |                |                   |   |     |     |      |   |      |     |      |   |      |   |      |   |      |   |       |
| <b>Pressure sensors</b>             | VDO, range 50 to 1000 ohms, 10 bar. Rotax 912/914 standard sender is 200 ohms<br>VDO senders used to measure fuel pressure require the fuel isolation kit available from VDO<br>Linear types from 1bar to 10bar 0V-05V range, pull-up resistor in instrument is 1K5 to 5V<br>User defined senders: TP-1 has a sender calibration feature<br><br><b>VDO Bar/Resistance curve for 10 Bar pressure sender</b>   |                |                   |   |     |     |      |   |      |     |      |   |      |   |      |   |      |   |       |
|                                     | <table border="1" style="margin-left: auto; margin-right: auto;"> <thead> <tr> <th>Pressure (Bar)</th> <th>Resistance (Ohms)</th> </tr> </thead> <tbody> <tr><td>0</td><td>7.2</td></tr> <tr><td>0.5</td><td>18.2</td></tr> <tr><td>1</td><td>28.2</td></tr> <tr><td>1.5</td><td>39.2</td></tr> <tr><td>2</td><td>49.2</td></tr> <tr><td>3</td><td>68.2</td></tr> <tr><td>4</td><td>87.2</td></tr> <tr><td>5</td><td>104.2</td></tr> </tbody> </table> | Pressure (Bar) | Resistance (Ohms) | 0 | 7.2 | 0.5 | 18.2 | 1 | 28.2 | 1.5 | 39.2 | 2 | 49.2 | 3 | 68.2 | 4 | 87.2 | 5 | 104.2 |
| Pressure (Bar)                      | Resistance (Ohms)  |                |                   |   |     |     |      |   |      |     |      |   |      |   |      |   |      |   |       |
| 0                                   | 7.2  |                |                   |   |     |     |      |   |      |     |      |   |      |   |      |   |      |   |       |
| 0.5                                 | 18.2   |                |                   |   |     |     |      |   |      |     |      |   |      |   |      |   |      |   |       |
| 1                                   | 28.2   |                |                   |   |     |     |      |   |      |     |      |   |      |   |      |   |      |   |       |
| 1.5                                 | 39.2   |                |                   |   |     |     |      |   |      |     |      |   |      |   |      |   |      |   |       |
| 2                                   | 49.2   |                |                   |   |     |     |      |   |      |     |      |   |      |   |      |   |      |   |       |
| 3                                   | 68.2   |                |                   |   |     |     |      |   |      |     |      |   |      |   |      |   |      |   |       |
| 4                                   | 87.2   |                |                   |   |     |     |      |   |      |     |      |   |      |   |      |   |      |   |       |
| 5                                   | 104.2  |                |                   |   |     |     |      |   |      |     |      |   |      |   |      |   |      |   |       |

|  |  |     |       |
|--|--|-----|-------|
|  |  | 6   | 121.2 |
|  |  | 7   | 137.2 |
|  |  | 8   | 153.2 |
|  |  | 8.5 | 160.2 |
|  |  | 9   | 167.2 |
|  |  | 10  | 181.2 |

## 9 Installation

### Temperature senders

Four types of senders can be fitted:

**Water temperature senders (NTC types):** A suitable sender with the same thread used by Rotax can be obtained from MGL Avionics. If you source your own sender, ensure that it has the following characteristics: 900 Ohms at 20 degrees C and 93 ohms at 85 degrees C.

**Oil temperature senders (NTC types):** A standard automotive sender as fitted by Rotax to 912/914 engines can be used. It has the following characteristics: Resistance of 100 ohms at 85 degrees C and 1000 ohms at 20 degrees C.

**MGL Precision senders:** These are senders containing a semiconductor temperature measurement device. They can be used for water or oil temperature. These senders are available in two types: an encapsulated version with a brass housing suitable for Rotax thread; a second uncommitted version contains only the sensor itself. This can be conveniently mounted inside an existing sender housing after you remove the original insides of the sender. This is intended to give you a solution for unusual or difficult to obtain senders.

Most NTC senders require a single wire connected as shown. The sender is grounded via the engine block. The ground terminal of the gauge input should be connected to the engine block. Some NTC senders have two wires. In this case it is not required that the sender housing itself is connected to the engine block. Wire the second wire to the reference ground terminal.

**User defined senders:** The TP-1 allows for the calibration of user defined senders.

### Pressure senders

Pressure senders come in two basic varieties. The first are the automotive types (for example from VDO), the second are the electronic types with linear output. Most pressure senders used for engines are piezo-resistive types. These tend to have a very low resistance at low pressures and a high resistance at their maximum pressure output. The resistance is approximately linear with pressure. The TP-1 supports both increased resistance with pressure as well as decrease resistance with pressure types. The TP-1 allows you to choose the pressure sender type as described in the relevant section of this manual. Most automotive types have resistance ranges from 200 to 400 ohms. For example: the oil pressure sender as installed in a Rotax 912/914 engine has approx. 200 ohm resistance for 10 bars pressure.

Linear output senders that can be used with the TP-1 are those types that have their maximum output voltage of 5V at their maximum pressure output. This can be selected in the TP-1 from 1 to 10 bars.

Senders can have either one or two wires, the two wire senders need one connection to ground. Wire them up as indicated in the drawing. Please note that two wire senders may be sensitive to polarity. One of the two wires is a dedicated ground terminal that has to be connected to ground (minus of the battery or engine block).

### Senders that are grounded in the engine block

Single wire senders require that their mounting arrangement (thread) has a very good electrical contact with the engine block. Avoid the use of any sealant or tapes as these may cause a bad electrical connection. Further to this it is very important that the engine block has a good electrical connection to the negative supply terminal of the TP-1. Any voltage drop caused by other equipment on the ground wire will cause incorrect readings. The best way to ensure a good connection is to wire a single connection between the TP-1 ground terminal (any of these terminals) and the engine block. Do not wire this anywhere else and do not allow any other equipment to use this wire as a current return path.

### 9.1 Connection Diagram

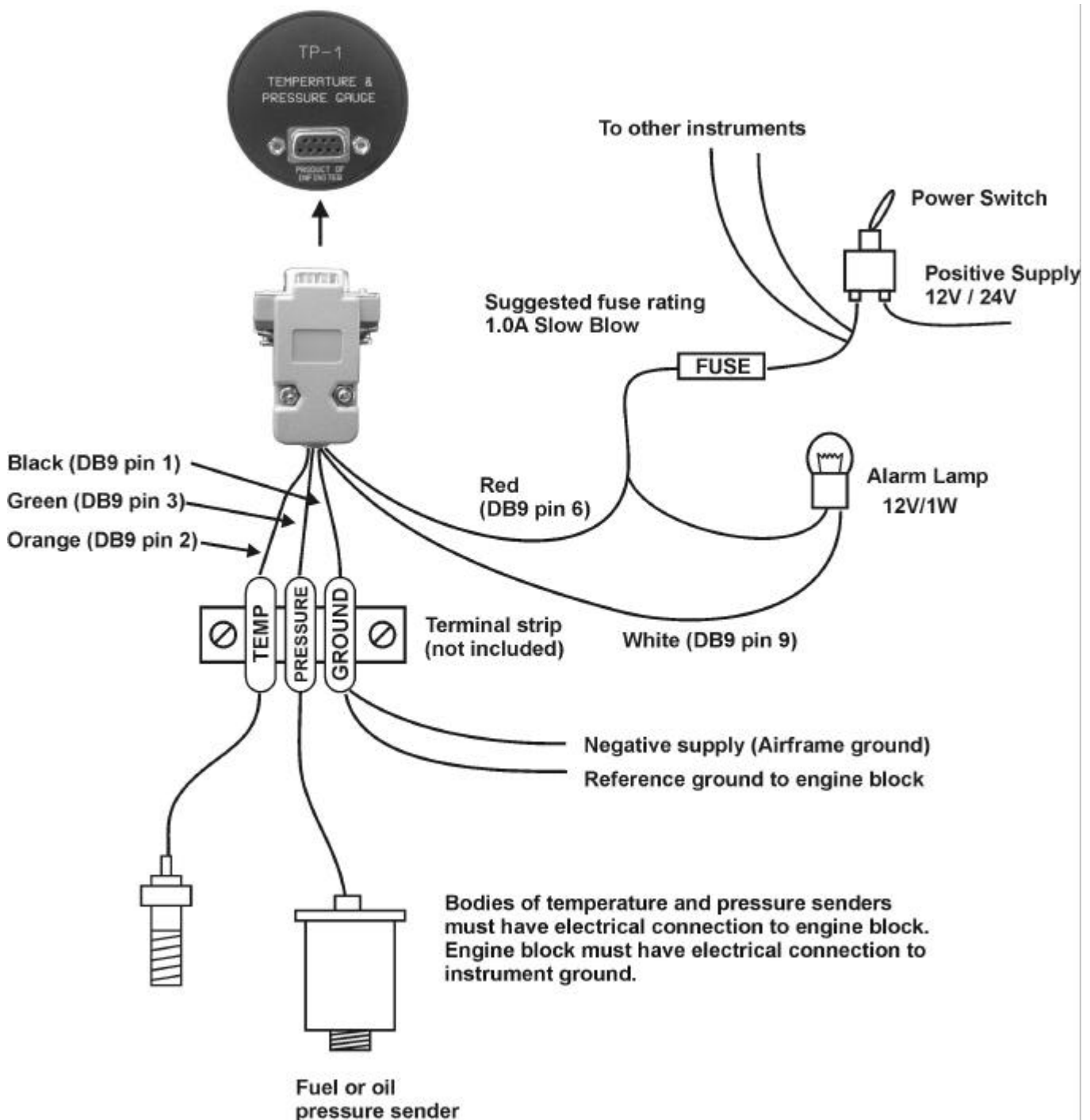

The use of an external 1A fuse is recommended. Connect the supply terminals to your aircrafts power supply. The TP-1 can be used on both 12V and 24V without the use of any pre-regulators. Ensure that the supply voltage will not drop below 8V during operation as this may result in incorrect voltage and or current readings.

## 9.2 TP-1 DB9 Cable connections

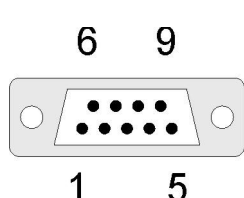

| DB 9 Pin | Color  | Function   |
|----------|--------|--|
| 1        | Black  | Ground   |
| 2        | Orange | Temperature Sender input   |
| 3        | Green  | Pressure Sender input  |
| 4        | NC     | Airtalk communication (Not connected)<br>Used for firmware upgrading |
| 6        | Red    | 8-30Vdc power  |
| 9        | White  | Alarm Output   |

## 10 Warranty

This product carries a warranty for a period of one year from date of purchase against faulty workmanship or defective materials, provided there is no evidence that the unit has been mishandled or misused. Warranty is limited to the replacement of faulty components and includes the cost of labour. Shipping costs are for the account of the purchaser.

**Note:** Product warranty excludes damages caused by unprotected, unsuitable or incorrectly wired electrical supplies and or sensors, and damage caused by inductive loads.

## 11 Disclaimer

Operation of this instrument is the sole responsibility of the purchaser of the unit. The user must make themselves familiar with the operation of this instrument and the effect of any possible failure or malfunction.

This instrument is not certified by the FAA. Fitting of this instrument to certified aircraft is subject to the rules and conditions pertaining to such in your country. Please check with your local aviation authorities if in doubt. This instrument is intended for ultralight, microlight, homebuilt and experimental aircraft. Operation of this instrument is the sole responsibility of the pilot in command (PIC) of the aircraft. This person must be proficient and carry a valid and relevant pilot's license. This person has to make themselves familiar with the operation of this instrument and the effect of any possible failure or malfunction. Under no circumstances does the manufacturer condone usage of this instrument for IFR flights.

The manufacturer reserves the right to alter any specification without notice.

## Other instruments in the Stratomaster Infinity series

|              |   |
|--------------|---|
| <b>ALT-1</b> | Precision encoding altimeter and vertical speed indicator                   |
| <b>ASI-1</b> | Airspeed indicator (ASI) with automatic flight log                          |
| <b>ASX-1</b> | Encoding aviation altimeter with serial output and airspeed indicator (ASI) |
| <b>AV-1</b>  | Artificial horizon and magnetic compass indicator                           |
| <b>BAT-1</b> | Battery voltage and current monitor   |
| <b>E-3</b>   | Universal engine monitor  |
| <b>FF-1</b>  | Fuel Computer (single or dual fuel tanks)                                   |
| <b>GF-1</b>  | +/-10G tilt compensated dual range G-force meter                            |
| <b>MAP-1</b> | Universal pressure indicator  |
| <b>RV-1</b>  | Universal engine RPM and rotor RPM Indicator                                |
| <b>RTC-2</b> | Aviation real time clock (RTC) and outside air temperature (OAT) display    |
| <b>TC-1</b>  | 4-Channel thermocouple indicator  |
| <b>TP-1</b>  | Universal temperature and pressure gauge                                    |